

Competition Series Solid Shooting Booth

Models SBC1000, SBC1000B, SBC1000R/L, SBC1000BR/BL

mancom
MANUFACTURING INCORPORATED

TECHNICAL DATA

AT A GLANCE

- Constructed of steel covered with ballistic rubber panels
- Solid booth provides the privacy needed for concentration
- Shooting Booth Shelf (SBB1100) and Swing-Out Barrier (SBB1200) are available as optional accessories
- Local Control Screen (LCS1100) mounts to booth frame

DESCRIPTION:

The solid shooting booth divider is constructed of rectangular steel tubing around steel plate, covered with ballistic rubber panels for safety and sound reduction. The booth is compatible with the full-width Shooting Booth Shelf (SBB1100) and the Swing-Out Barrier (SBB1200). The solid booth divider keeps shooters safe from one another's rounds while providing privacy for training and competition purposes.

FINISH:

Frame: Pebbled Black Powder Coat
Rubber: Black

SIZE:

SBC1000, SBC1000B:
52.00"L x 3.25"TH x 100.00"H

SBC1000R/L, SBC1000BR/BL:
52.00"L x 3.13"TH x 100.00"H

WEIGHT:

SBC1000: 691 lbs
SBC1000B: 696 lbs
SBC1000R/L: 528 lbs
SBC1000BR/BL: 533 lbs

INNOVATION. NOT IMITATION.

Competition Series Solid Shooting Booth

Models SBC1000, SBC1000B, SBC1000R/L, SBC1000BR/BL



ARCHITECTS' & ENGINEERS' SPECS

The Competition Series booth divider shall be designed to separate shooters on the firing line for training purposes. It shall also provide the shooter with privacy to allow concentration while doing precision shooting. The divider frame shall be constructed of 2" x 3" rectangular steel tubing around a 1/4" mild steel protection plate. This inner plate shall be covered with 1.5" thick ballistic rubber panels. The ballistic rubber shall trap stray rounds and shall assist in attenuating noise levels. The rear post shall attach to the lateral beam, which is used as a low-voltage wiring chase. The booth shall be fastened to the floor with appropriate anchors.

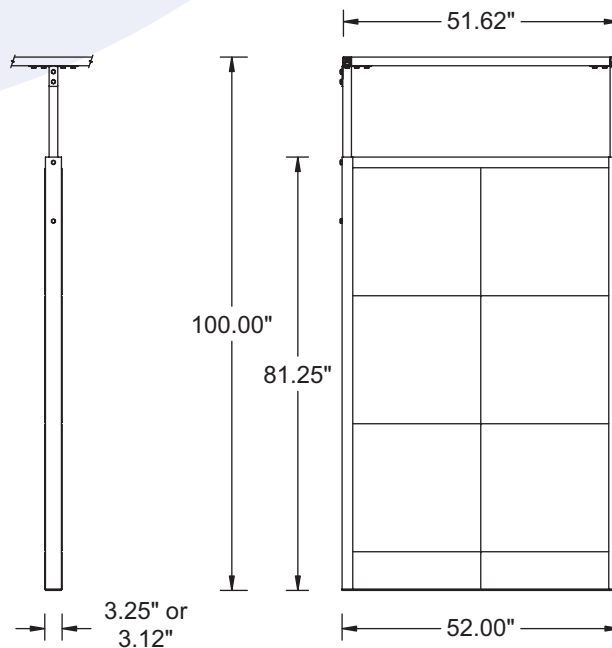

All specifications and design details are subject to change without prior notice. All rights reserved. © 11.04

INNOVATION. NOT IMITATION.